



# Photo & Memento Organization

## Week 10 - 12 Week Get Organized Challenge

### Week 10 – Photos & Mementos

Keeping your photos and mementos organized can be the difference between getting pages done or becoming overwhelmed.

This week we'll begin the process of sorting both your printed and digital photos, along with rounding up all of those wayward mementos.



#### What you need:

- ❑ Storage for photos – Classis photo storage boxes, 4x6 or 5x7 Fab Files
- ❑ Storage for Mementos – large envelopes, Memento Keepers, Album Storage Fab Files, 12x12 Fab Files
- ❑ Computer storage system for your digital photos – most computers include something for photo storage, but I just use regular files.
- ❑ Labels / Sticky notes
- ❑ Plain paper for creating sorting guides.
- ❑ Family timeline/journal/spreadsheets, etc

#### What to do:

##### Basic sorting and storage



- ✓ [Create a family timeline](#) to easily organize photos.
- ✓ Sort your photos into chronological order – either in photo storage boxes or digitally.
- ✓ Create sorting guides for fast and easy sorting.
- ✓ Use sticky notes on the back side of your photos to easily label dates/events.
- ✓ Create individual Event Notes & Details sheets when appropriate. (download – [Landscape](#) or [Portrait](#))

- ✓ Add labels to the boxes/digital photos. Be consistent with labeling – a “perpetual” or birthday calendar can help.
- ✓ Sort the mementos chronologically as well.
- ✓ If you're not storing your photos and mementos together, include notes with the photos about the memento location and vice versa.
- ✓ Organize photo boxes chronologically.



11	
12	
13	Tina's Birthday (Tina) 1964
14	
15	
16	
17	
18	
19	
20	
21	Max's Birthday (Max) 1998
22	

10	
11	
12	
13	
14	Valentine's Day (Vday)
15	
16	
17	
18	
19	
20	

1. Week 10 – Organize Photos & Mementos, plan a project

[The Organized Crafter / Creative Scrapbooker Magazine 12 Week Get Organized Challenge](#)

**Next level organizing**

Getting photos organized chronologically is the first step. The next step is separating the photos you'll actually scrap from the photos you won't. You may be able to do this as you're sorting the first time through – if so, that will help when you're ready to create your project plan.

**Creating a holding album/project plan**

- Decide how many photos you'll use on a page.
- Decide how many pages you'll create for a particular album/event/holiday, etc.
- Create a project planner by combining the pictures and mementos into a single "holding album."
- Add your event planner sheets and [Jill's layout planner](#).
- When you're ready to create scrapbook pages, everything will be organized and ready.



**Creating multiple albums at the same time**

If you're creating multiple similar albums at the same time [use my album planner grid](#) to create an easy reference for sorting, organizing, and completing the albums.

One note from my experience – I created separate albums for London and Max (my sons) as well as a set of family albums. When I go...who will want the family albums? It may have been better to do 2 sets of albums total and then given one set to each of the boys as they were ready.

Notes:

---

---

---

---

---

---

---

---

---

---



# Photo & Memento Organization Challenge Checklist

Week 10 - 12 Week Get Organized Challenge

- Create a family timeline – spreadsheet, on the wall, in a notebook
- Gather your photos both physically and digitally
- Choose photo storage solutions
- Create sorting guides and/or use Event Note & Details (download Landscape or download Portrait)
- Organize 1 year of photos chronologically – more if you can get family member to help you. Don't forget to have a notepad or family timeline next to you while you go through this process.
- Gather mementos
- Choose storage solutions
- Organize 1 year of mementos chronologically
- If you're ready – put together your first project/album planner.
- Enjoy your reward.
- Enter this week's contest.

# Totally-Tiffany Product Options



Choosing the perfect storage options is a personal preference. I prefer to use smaller storage boxes like Fab Files for photos as it makes it less overwhelming to choose what to work on and easier to grab a small box rather than a large box.

Binders also simplify the process when it comes to setting up an album/project as you can see everything visually and get a good idea of the layout and what you might need to complete it. If you scrap in 12x12 binders are also a simple place to store completed pages until you're ready to add them to an album.

## Binder systems for Project Planning and Memento Storage

### [Memento Keeper / Project Planner](#)

12x12 Binder pre-loaded with 3 Project Planner Pages. Large gusseted pockets are located on the inside covers of the binder.



## **Create your own 12x12 Project Planner Binder**

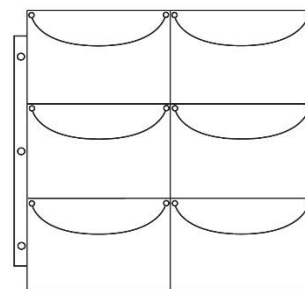

[12x12 Binder](#)

[Project Planner Pages](#)

[4x6 Photo Storage Page](#)

4. Week 10 – Organize Photos & Mementos, plan a project

[The Organized Crafter / Creative Scrapbooker Magazine 12 Week Get Organized Challenge](#)

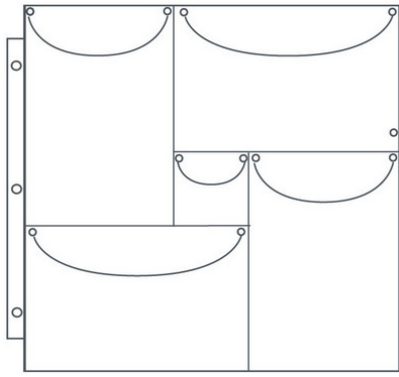

[5x7 Photo Storage Page](#)

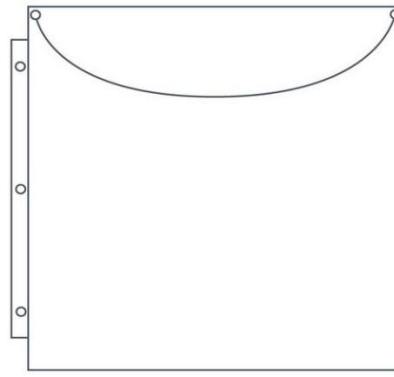

[12x12 Memento & Supply](#)

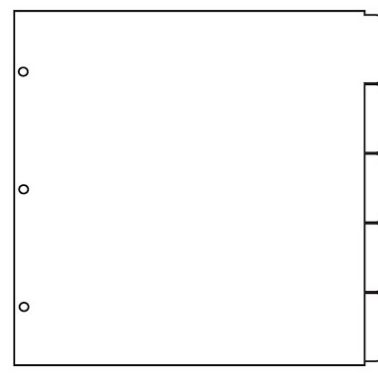

[Dividers](#)

## Memento Storage Boxes

The Album Storage Fab Files are wonderful memento storage boxes. Big and roomy they can be organized using our 12x12 Tabbed Divider Pockets.



[Album Storage Fab File](#)



[3 Ring Album Storage Fab File](#)



[12x12 Tabbed Divider Pockets](#)

## Photo Storage

The 4x6 and 5x7 Fab File are perfect photo storage. Choose to use either the photo files or tabbed divider pockets.



[4x6 Fab File with Photo Files](#)



[4x6 Fab File with pockets](#)



[4x6 pockets](#)

5. Week 10 – Organize Photos & Mementos, plan a project

[The Organized Crafter / Creative Scrapbooker Magazine 12 Week Get Organized Challenge](#)



[5x7 Fab File with Photo Files](#)



[5x7 Fab File with pockets](#)



[5x7 pockets](#)

Links included in this handout:

[Album-Planning-Grid.pdf \(totally-tiffany.com\)](#)

[Event Notes and Details – Landscape Orientation](#)

[Event Notes and Details – Portrait Orientation](#)

[Jill's Layout Planner](#)

[4 Digital Photo Organization Tips](#)

[How to create a family timeline for photo sorting](#)

6. Week 10 – Organize Photos & Mementos, plan a project

[The Organized Crafter / Creative Scrapbooker Magazine 12 Week Get Organized Challenge](#)